



曁俊工業

YEH CHIUN

YEH CHIUN INDUSTRIAL

**HIGH PRECISION
HYDRAULIC
PRESS BRAKE
SERIES**

高精密油壓折床系列

YEH CHIUN



追求卓越品質，精益求精 提升競爭優勢，永續經營

*Pursuit for outstanding quality and continuous improvement
Upgrade competitive advantage for everlasting business*

創立於1984年，晔俊工業以生產精密、高品質的油壓工具機著稱，在業界建立良好的商譽及口碑。

採用業界最高規格零組件，搭配世界頂尖的控制器及油壓系統，數十年來所累積的研發設計經驗，加上晔俊一直以來對更高階技術的追求，這一切使我們的油壓折床得以持續不斷地升級，並滿足各個不同客戶的需求。

晔俊工業提供專業、客製化、高性價比的產品，輔以完整確實的售後服務；為客戶創造最大的價值，是我們對每一位客戶的承諾。

Established in 1984, Yen Chiun is one of the manufacturers in Taiwan of top-quality hydraulic machines. Our company has developed a worldwide reputation for honesty and reliability in the sheet metal fabrication industry over the years.

With high-quality components and parts, world-famous controls and top hydraulic systems, our decades' R&D experiences, Yeh Chiun still keeps pursuing higher level of technology application in the hope that we can continuously upgrade our hydraulic press brakes and satisfy customers with various need.

Yen Chiun offers professional, customized, cost-effective products and the best reliable after-sales service. To create the most value to your business is the promise we give to all our business partners and clients.



CNC 油壓折床控制系統

CNC Hydraulic Press Brake Controller System

DELEM DA-66T 功能簡介

1. 17" TFT 真彩觸控螢幕
2. 全螢幕觸控式操作
3. 2D觸控式圖形編程
4. 3D產品圖形顯示
5. 自動折彎干涉/碰撞檢測功能
6. 自動計算折彎工序
7. 簡潔單頁式編程操控
8. 模具資料庫(圖像編程 及 圖像顯示)
9. 模具安全區域計算
10. 16 軸控制

DELEM DA-66T Features

1. 17" colour TFT touch screen
2. Full screen touch control
3. 2D graphic program by touch-screen control
4. 3D product graph display
5. Automatic collision detection
6. Automatic sequence computation
7. One page programming table
8. Graphic tooling library (graphic program & display)
9. Tooling safety zone
10. 16 axes available



DELEM DA-58T 功能簡介

1. 15" TFT 真彩觸控螢幕
2. 全螢幕觸控式操作
3. 2D觸控式圖形編程
4. 3D產品圖形顯示
5. 自動計算折彎工序
6. 自動折彎干涉/碰撞檢測功能
7. 簡潔單頁式編程操控
8. 模具資料庫(圖像編程 及 圖像顯示)
9. 模具安全區域計算
10. 5 軸控制

DELEM DA-58T Features

1. 15" colour TFT touch screen
2. Full screen touch control
3. 2D graphic programming by touch-screen control
4. 3D product graph display
5. Automatic sequence computation
6. Automatic collision detection
7. One page programming table
8. Graphic tooling library (graphic program & display)
9. Tooling safety zone
10. 5 axes available

CYBELEC MODEVA 19T 功能簡介

1. 19" TFT 真採觸控螢幕
2. 2D觸控式圖形編程
3. 單頁式編程操控
4. 最佳折彎工序建議
5. 模具資料庫
6. 18軸控制
7. 隨機附帶離線軟體PC-ModEva

CYBELEC MODEVA 19T Features

1. Large 19" colour TFT touch screen
2. 2D graphic programming by touch-screen control
3. One page programming table
4. Optimize bending steps
5. Tooling library
6. 18 axes available
7. Delivered with off-line PC-ModEva software



CYBELEC MODEVA PAC 功能簡介

1. 2D觸控式圖形編程
2. 單頁式編程操控
3. 大尺寸按鍵面板
4. 最佳折彎工序建議
5. 模具資料庫
6. 7軸控制
7. 隨機附帶離線軟體PC-ModEva

CYBELEC MODEVA PAC Features

1. 2D graphic programming by touch-screen control
2. One page programming table
3. Keyboard with large keys
4. Optimize bending steps
5. Tooling library
6. 7 axes available
7. Delivered with off-line PC-ModEva software

CNC 油壓折床 YCN系列

CNC Hydraulic Press Brake YCN Series



CNC 油壓折床標準配備 (4軸以上)

CNC Hydraulic Press Brake Standard Accessories (4 Axes)

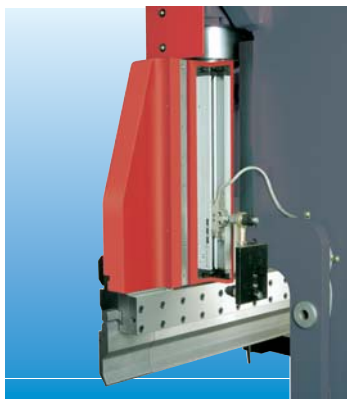

歐製光學尺
Euro Optical Scale

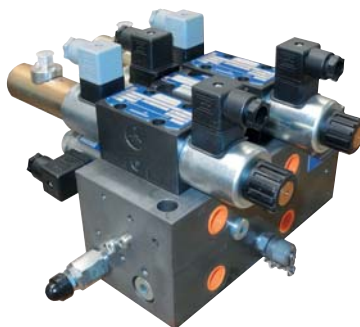

整組德國原裝液壓伺服系統 (霍爾比格)
Hydraulic Servo Valve System (Hoerbiger)

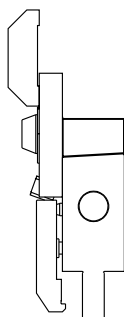
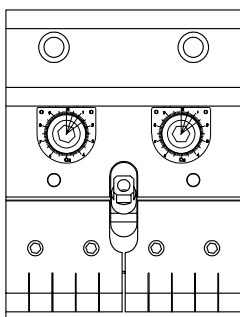
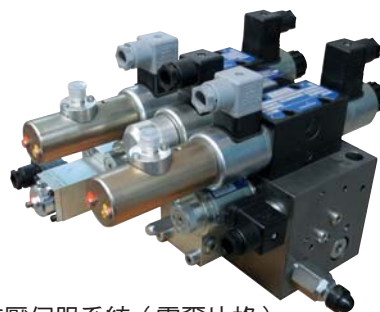

安全快速夾具系統 (手動)
Quick-release Safety Clamp (Manual)

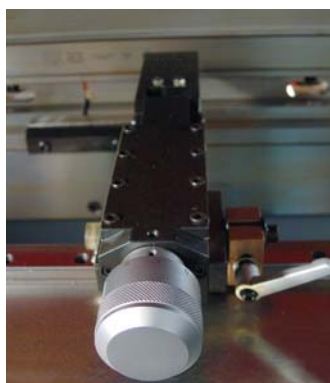

後規定位微調器
Micro Adjuster for Back Gauge



CNC 精密後規
CNC Precision Back Gauge



前規定位微調器
Positioning Device with Front Material Support



滑行式前扶料架
Slide Front Material Support

CNC 油壓折床選購配備

CNC Hydraulic Press Brake Optional Accessories

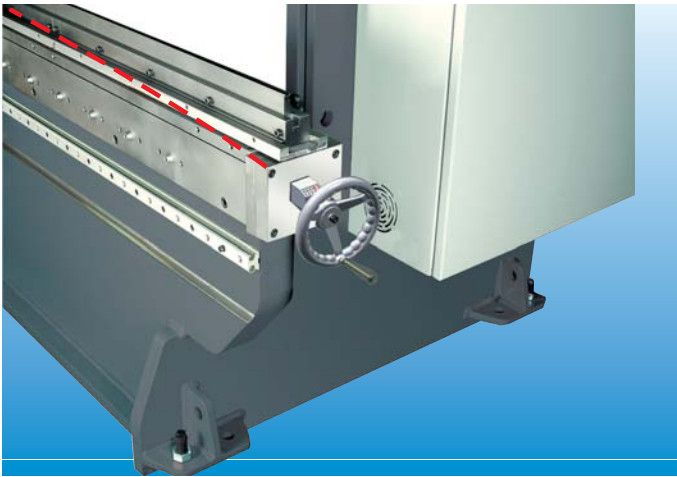

手動撓曲補償系統
Manual Crowning Compensation System

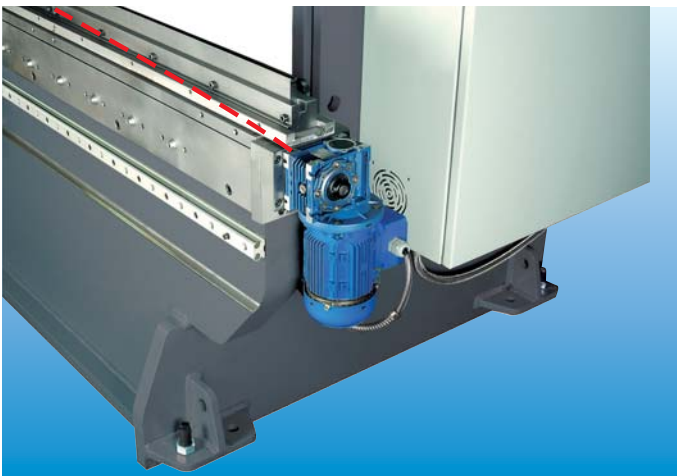
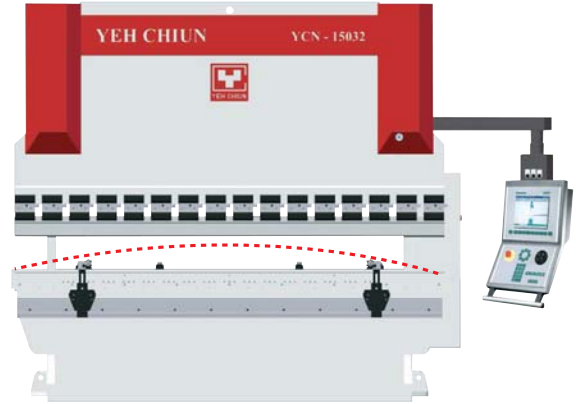

自動撓曲補償系統
Automatic Crowning Compensation System



油壓式撓曲補償系統
Hydraulic Crowning Compensation System

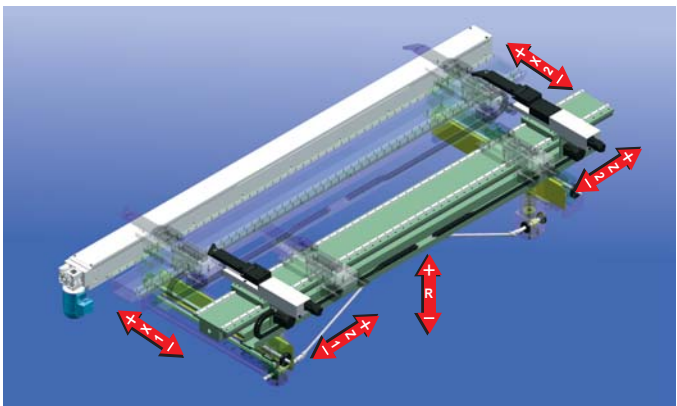

後規多軸選配：X1, X2, Z1, Z2, R1, R2,
Back Gauge Optional Axes: X1, X2, Z1, Z2, R1, R2,



隨動扶料系統
Automatic Sheet Follower

CNC 油壓折床選購配備

CNC Hydraulic Press Brake Optional Accessories

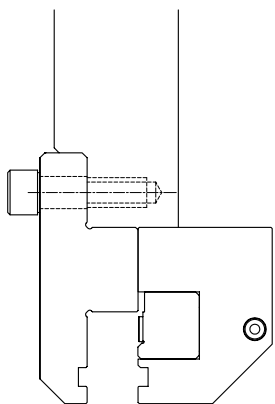

自動油壓夾具系統
Auto Hydraulic Clamping System

各式選配模具
Varied Tooling Packages



PILZ 安全攝像系統
PILZ Safety Camera



AKAS 安全雷射系統
AKAS Safety Laser



SICK 安全光柵
SICK Safety Light Curtain



側方活動式安全護欄
Movable Safety Side Fence



後方安全門
Safety Rear Door



DA-66T / DA-65W / DA-58T CNC 規格 (4軸以上) DA-66T / DA-65W / DA-58T CNC Specification (4 Axes)

型式 Type (Model) DA SYSTEM	曲折能力 Capacity (SS400) (mm)	衝壓能力 Max. Pressure (Ton)	馬力 Motor (HP)	A 台面長 Table Length (mm)	B 台面寬 Table Width (mm)	C 台面內距 Distance Between Housing (mm)	D 最大開距 Daylight (mm)	E 行程 Stroke (mm)	F 喉深 Throat (mm)	下降速度 Lowering Speed (mm/s)	加壓速度 Pressing Speed (mm/s)	回昇速度 Return Speed (mm/s)
YCN-5016	3.5X1600	50	7.5	1600	100	1220	450	250	400	180	12	160
YCN-6020	4.0X2000	60	7.5	2000	100	1600	450	250	400	180	12	160
YCN-8020	5.0X2000	80	10	2000	100	1600	450	250	400	180	12	160
YCN-8025	4.0X2500	80	10	2500	100	2100	450	250	400	180	12	160
YCN-10025	4.5X2500	100	15	2500	100	2100	450	250	400	180	12	160
YCN-10032	3.5X3200	100	15	3200	100	2600	450	250	400	180	12	160
YCN-10042	3.0X4200	100	15	4200	100	3400	450	250	400	180	12	160
YCN-12025	5.5X2500	120	15	2500	100	2100	450	250	400	180	12	160
YCN-12032	4.0X3200	120	15	3200	100	2600	450	250	400	180	12	160
YCN-15025	7.0X2500	150	20	2500	100	2020	450	250	400	180	12	160
YCN-15032	5.8X3200	150	20	3200	100	2600	450	250	400	180	12	160
YCN-15042	4.5X4200	150	20	4200	100	3400	450	250	400	180	12	160
YCN-15050	3.5X5000	150	20	5000	100	4200	450	250	400	180	12	160
YCN-20032	7.0X3200	200	25	3200	150	2600	450	250	400	180	10	160
YCN-20042	6.0X4200	200	25	4200	150	3400	450	250	400	180	10	160
YCN-20050	5.0X5000	200	25	5000	150	4200	450	250	400	180	10	160
YCN-20060	4.0X6000	200	25	6000	150	5200	450	250	400	180	10	160
YCN-25032	8.0X3200	250	25	3200	150	2600	550	300	400	180	10	160
YCN-25042	7.0X4200	250	25	4200	150	3200	550	300	400	180	10	160
YCN-25050	5.5X5000	250	25	5000	150	4000	550	300	400	180	10	160
YCN-30032	11X3200	300	40	3200	150	2600	550	300	400	100	10	90
YCN-30042	8.5X4200	300	40	4200	150	3200	550	300	400	100	10	90
YCN-30050	7.0X5000	300	40	5000	150	4000	550	300	400	100	10	90
YCN-30060	6.0X6000	300	40	6000	150	5000	550	300	400	100	10	90
YCN-40032	15X3200	400	50	3200	150	2600	550	300	400	100	7	90
YCN-40042	12X4200	400	50	4200	150	3200	550	300	400	100	7	90
YCN-40050	10X5000	400	50	5000	150	4000	550	300	400	100	7	90
YCN-40060	8.0X6000	400	50	6000	150	5000	550	300	400	100	7	90
YCN-50042	15X4200	500	60	4200	300	3200	550	300	400	100	6	70
YCN-50050	12X5000	500	60	5000	300	4000	550	300	400	100	6	70
YCN-50060	10X6000	500	60	6000	300	5000	550	300	400	100	6	70
YCN-60042	18X4200	600	60	4200	300	3200	600	350	400	100	6	70
YCN-60050	15X5000	600	60	5000	300	4000	600	350	400	100	6	70
YCN-60060	12X6000	600	60	6000	300	5000	600	350	400	100	6	70
YCN-70050	18X5000	700	75	5000	300	4000	600	350	400	100	6	65
YCN-70060	14X6000	700	75	6000	300	5000	600	350	400	100	6	65
YCN-80050	20X5000	800	100	5000	300	4000	600	350	400	100	6	65
YCN-80060	16X6000	800	100	6000	300	5000	600	350	400	100	6	65
YCN-90050	22X5000	900	100	5000	300	4000	600	350	400	100	6	60
YCN-90060	18X6000	900	100	6000	300	5000	600	350	400	100	6	60
YCN-100050	25X5000	1000	125	5000	300	4000	600	350	400	100	6	60
YCN-100060	20X6000	1000	125	6000	300	5000	600	350	400	100	6	60

為符合TS安全規範，加壓速度將被限制在10mm/sec以內。 In compliance with TS safety regulation, pressing speed would be limited below 10mm/sec.

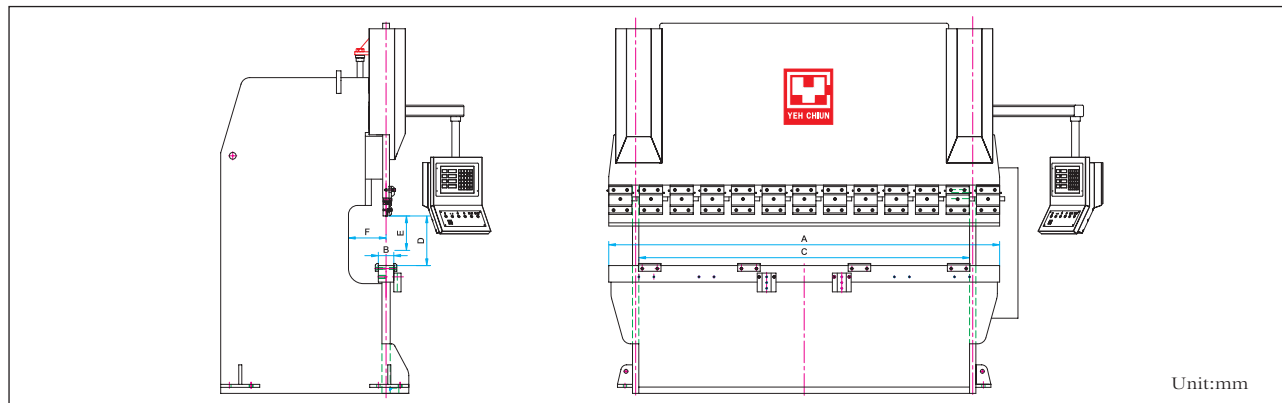

★本公司不斷研究改進，若規格有任何更改，恕不另行通知。 The specifications are subject to change without prior notice as a result of our continuing R&D.

CNC/ NC 油壓折床 YCN系列 CNC/ NC Hydraulic Press Brake YCN Series



CNC/ NC 油壓折床控制系統

CNC/ NC Hydraulic Press Brake Controller System

DELEM DA-52S 功能簡介

1. 7 “ TFT 彩色螢幕顯示
2. 快速單頁式編程操控
3. 折彎角度校正功能
4. 數據式編程
5. 模具安全區域
6. 模具資料庫
7. 三軸控制(Y, X, R)

DELEM DA-52S Features

1. 7” colour LCD display
2. Quick one-page programming
3. Angle correction database
4. Numerical programming
5. Tool library
6. Tooling safety zones
7. 3 axes control (Y, X ,R)



CybTouch 6 功能簡介

1. 5.7 “ CRT 彩色觸控螢幕
2. 觸控式數據編程
3. 人性化操控介面
4. 折彎角度校正功能
5. 模具資料庫
6. 產品資料庫
7. 雙軸控制(Y, X)

CybTouch 6 Features

1. 5.7” colour CRT touch screen
2. Touch screen numerical programming
3. Intuitive, friendly interface
4. Angle correction database
5. Tool library
6. Product library
7. 2 axes control (Y, X)

NC-05 功能簡介

1. LED數字顯示
2. 中英文操作面板
3. 可儲存150組程式
4. 折彎角度補正設定
5. X軸控制

NC-05 Features

1. LED numerical display
2. Operation panel: Chinese/ English characteristics
3. Up to 150 programs available
4. Bending angle correction setting
5. X axis control



傳統油壓折床 YCA系列

Conventional Hydraulic Press Brake YCA Series

- ▶ 折彎角度數值化控制
Numerical Bending Angle Control
- ▶ 手動後規
Manual Back Gauge

CNC DA-52S (3軸) / CybTouch 6 (2軸) / NC-05 / YCA 規格 CNC DA-52S (3 Axes) / CybTouch 6 (2 Axes) / NC-05 / YCA Specification

型 式 Type (Model)	曲折能力 Capacity (SS400) (mm)	衝壓能力 Max. Pressure (Ton)	馬力 Motor (HP)	A 台面長 Table Length (mm)	B 台面寬 Table Width (mm)	C 台面內距 Distance Between Housing (mm)	D 最大開距 Daylight (mm)	E 行程 Stroke (mm)	F 喉深 Throat (mm)	下降速度 Lowering Speed (mm/s)	加壓速度 Pressing Speed (mm/s)	回昇速度 Return Speed (mm/s)
YCN-3013	2.5X1300	30	3	1300	100	1000	350	180	320	135	10	90
YCN-4516	3.2X1600	45	3	1600	100	1220	350	180	320	135	10	90
YCN-4520	2.5X2000	45	3	2000	100	1600	350	180	320	135	10	90
YCN-6020	4.0X2000	60	5	2000	100	1600	350	180	320	120	10	90
YCN-6025	3.0X2500	60	5	2500	100	2100	350	180	320	120	10	90
YCN-8020	5.0X2000	80	5	2000	100	1600	350	180	320	120	10	90
YCN-8025	4.0X2500	80	5	2500	100	2100	350	180	320	120	10	90
YCN-10025	4.5X2500	100	7.5	2500	100	2100	350	180	320	100	10	90
YCN-10032	3.5X3200	100	7.5	3200	100	2600	350	180	320	100	10	90
YCN-10042	3.0X4200	100	7.5	4200	100	3400	350	180	320	100	10	90
YCN-15025	7.0X2500	150	10	2500	150	2020	450	250	320	100	10	90
YCN-15032	5.8X3200	150	10	3200	150	2600	450	250	320	100	10	90
YCN-15042	4.5X4200	150	10	4200	150	3400	450	250	320	100	10	90
YCN-15050	3.5X5000	150	15	5000	150	4200	450	250	320	100	10	90
YCN-20032	7.0X3200	200	15	3200	250	2600	450	250	320	100	8-9	90
YCN-20042	6.0X4200	200	15	4200	250	3400	450	250	320	100	8-9	90
YCN-20050	5.0X5000	200	20	5000	250	4200	450	250	320	100	8-9	90
YCN-20060	4.0X6000	200	20	6000	250	5200	450	250	320	100	8-9	90
YCN-30032	11X3200	300	25	3200	300	2600	500	300	400	100	8-9	80
YCN-30042	8.5X4200	300	25	4200	300	3200	500	300	400	100	8-9	80
YCN-30050	7.0X5000	300	30	5000	300	4000	500	300	400	100	8-9	80
YCN-30060	6.0X6000	300	30	6000	300	5000	500	300	400	100	8-9	80
YCN-40032	15X3200	400	30	3200	300	2600	500	300	400	100	7	76
YCN-40042	12X4200	400	40	4200	300	3200	500	300	400	100	7	76
YCN-40050	10X5000	400	40	5000	300	4000	500	300	400	100	7	76
YCN-40060	8.0X6000	400	40	6000	300	5000	500	300	400	100	7	76
YCN-50042	15X4200	500	45	4200	400	3200	500	300	400	100	6	70
YCN-50050	12X5000	500	45	5000	400	4000	500	300	400	100	6	70
YCN-50060	10X6000	500	45	6000	400	5000	500	300	400	100	6	70

為符合TS安全規範，加壓速度將被限制在10mm/sec以內。 In compliance with TS safety regulation, pressing speed would be limited below 10mm/sec.

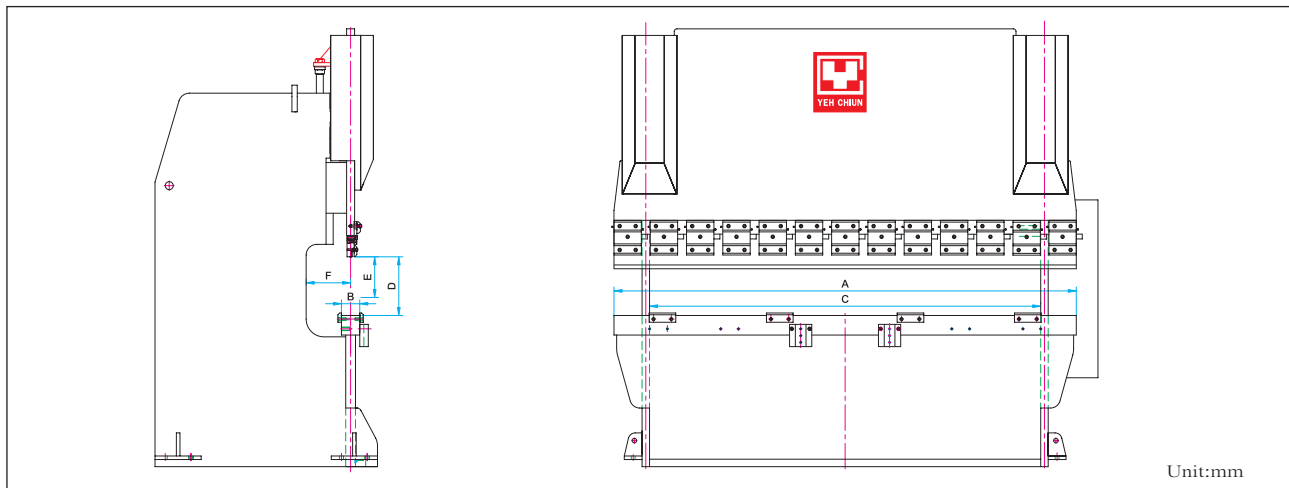

★本公司不斷研究改進，若規格有任何更改，恕不另行通知。The specifications are subject to change without prior notice as a result of our continuing R&D.

CNC 電機伺服馬達折床EPB系列 CNC Servo Motor Press Brake EPB Series



雙軸式
Twin-motor

規格 SPECIFICATION

Item 規格		型式 (Model)	EPB-2606	EPB-3813	EPB-5816	EPB-5820	EPB-8025
曲折能力	Capacity	(ton)	26	38	58	58	80
折曲長度	Bending Length	(mm)	600	1300	1600	2000	2500
行程	Stroke Length	(mm)	120	120	120	160	160
速度 Speed	下降 Lowering	(mm/s)	1~150	1~150	1~120	1~120	1~120
	加壓 Pressing	(mm/s)	0.2~20	0.2~20	0.2~20	0.2~20	0.2~20
	回昇 Return	(mm/s)	1~150	1~150	1~120	1~120	1~120
AC伺服馬達	AC servo motor / (Y)	(kw)	4.2				
AC伺服馬達	AC servo motor / (Y1,Y2)	(kw)		4.2	4.6	4.6	7.1
角度定位精度	Angle Positioning Accuracy	(mm)	±0.01	±0.01	±0.01	±0.01	±0.01
後規 Backgauge	馬達 AC servo motor	(kw)	0.7	0.7	0.7	0.7	0.7
	定位精度 Positioning Accuracy	(mm)	0.03	0.03	0.03	0.03	0.03
	速度 Speed	(m/min)	MAX. 30	MAX. 30	MAX. 30	MAX. 30	MAX. 30
	行程 Stroke	(mm)	480	480	480	480	480
R 軸行程	R axis stroke	(mm)	100	100	100	100	100
重量	N.W.	(kg)	2330	3000	3600	4000	6000

為符合TS安全規範，加壓速度將被限制在10mm / sec以內。

In compliance with TS safety regulation, pressing speed would be limited below 10mm / sec.

★本公司不斷研究改進，若規格有任何更改，恕不另行通知。

The specifications are subject to change without prior notice as a result of our continuing R&D.



單軸式
Single-motor

折床特別式樣 Varied Press Brake Available



CE安規油壓折床
Hydraulic Press Brake with CE Safety Standard



CE安規伺服折床
Servo Press Brake with CE Safety Standard



大型聯動折床
Tandem Press Brake



龍門型折床
Gate-frame Press Brake

折彎自動化

Total Automation Solutions of Bending

量多樣繁→全自動智能折彎工作站

High Variety, High Volume Production → Auto Bending Cell

- 1 折床
Press Brake
- 2 機械手臂
Robot
- 3 移動軌道
Track
- 4 板件定位裝置
Repositioning Device
- 5 材料區
Material Station
- 6 成品擺放區
Product Unloading Zone

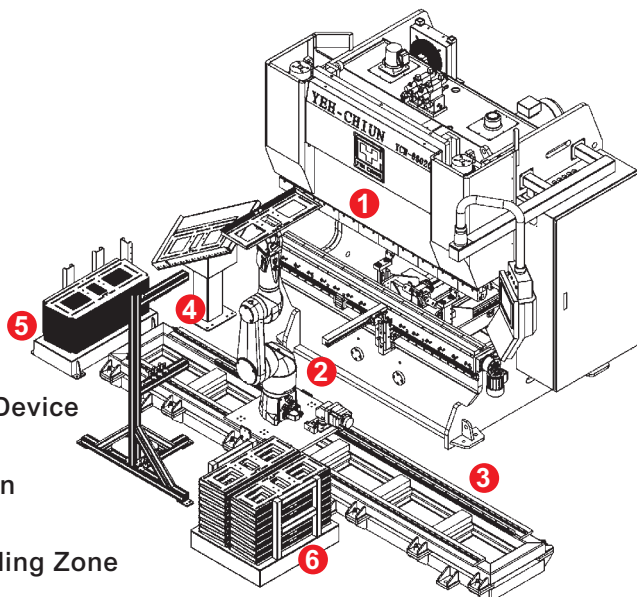

智能折彎工作站兼具制式化生產效能及個別化的運用彈性，可穩定，有效率地完成各種不同變化且複雜的折彎工程。自動化與智慧科技的結合，是未來邁向智慧工廠不可或缺的設備之一。

Auto bending cell has both the effectiveness of standardization and the total flexibility of personalization, capable of variety, complicated bending in constant speed. It is the combination of automatic and smart tech, one of the necessary factors of smart factory in the future.

量多樣少→全自動折彎產線

High Volume, Little Variation Production → Auto Bending Line



自動折彎產線適用於快速且大量標準化板金的生產，且板件成型尺寸可進行一定範圍內調整。為完全客製化設備，根據每一位客戶的不同需求進行規劃及設計。可在產能提升的同時，有效降低勞動力，進而增加經濟效益，為最佳生產利器。Auto bending line is used to produce large quantities of same sheet metal fabrication in short time, with ability of certain size variation. Complete customized, every auto bending line is engineered and designed to meet specific desires of each customer. Productivity efficiency with much lesser labor force, that enables profit growth. The best equipment for manufacturers.



TD0400H5



曄俊工業股份有限公司 YEH CHIUN INDUSTRIAL CO., LTD.

台灣一廠·台中市41463烏日區福泰街75號
OFFICE1: NO.75, FU TAI ST., WURI DIST., TAICHUNG CITY
41463, TAIWAN (R.O.C.)
TEL: +886-4-23352579 FAX: +886-4-23352773

台灣二廠·台中市41468烏日區大明路成豐巷42之8號
OFFICE2: NO.42-8, CHENG FENG LN., TAIMING RD., WURI DIST.,
TAICHUNG CITY 41468, TAIWAN (R.O.C.)
TEL: +886-4-23354705 FAX: +886-4-23352868

<http://www.yehchiun.com> E-mail: sales@yehchiun.com



經銷商(AGENT):

CNC / NC 折床 · 電機伺服折床 · 剪床 · 沖床 · 成型機 · 各式板金自動化設備
CNC / NC Hydraulic Press Brake, Servo Press Brake, Shear, Press, Forming Machines, Total Automation Solutions